

- ① COORDINATE DIMENSION APPLIES FROM BASIC LOCATION.
- ② 10 AND 14 POSITION SIZES CONTAIN ONLY ONE SLOT FOR SNAP-IN POLARIZER (MILITARY POLARIZATION) LOCATED AS SHOWN.
- ③ 10 POSITION SIZES CONTAIN ONLY ONE SLOT FOR DUAL POLARIZATION, LOCATED AS SHOWN.
- 4. RECOMMENDED PRINTED CIRCUIT BOARD THICKNESS IS 1.57 [0.062].
- ⑤ POSTS:
 GOLD FLASH OVER
 0.38μm [0.000015] MIN PALLADIUM-NICKEL PLATE ON THE LOCALIZED PLATE AREA,
 2.54μm [0.000100] MIN TIN-LEAD PLATE ON THE SOLDER-TAIL,
 1.27μm [0.000050] MIN NICKEL UNDERPLATE ON THE ENTIRE POST.
 OR
 0.38μm [0.000015] MIN GOLD PLATE ON THE LOCALIZED PLATE AREA,
 2.54μm [0.000100] MIN TIN-LEAD PLATE ON THE SOLDER-TAIL,
 1.27μm [0.000050] MIN NICKEL UNDERPLATE ON THE ENTIRE POST.
- ⑥ MATERIAL:
 HOUSING: GLASS FILLED POLYESTER, 94V-0 RATED, BLACK.
 POSTS: PHOSPHOR BRONZE OR BRASS.

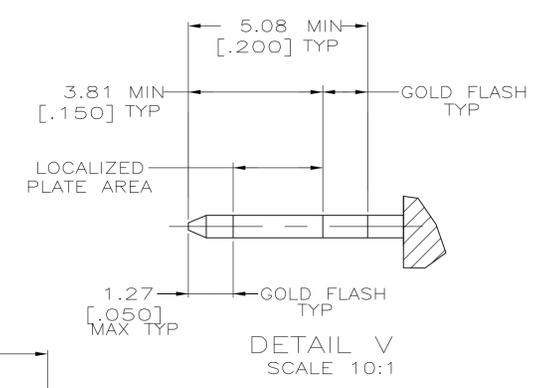

OBSOLETE

53.34	71.12	65.02	75.18	71.12	60.96	44	1-102153-3
[2.100]	[2.800]	[2.560]	[2.960]	[2.800]	[2.400]		
78.74	96.52	90.42	100.58	96.52	86.36	64	1-102153-2
[3.100]	[3.800]	[3.560]	[3.960]	[3.800]	[3.400]		
73.66	91.44	85.34	95.50	91.44	81.28	60	1-102153-1
[2.900]	[3.600]	[3.360]	[3.760]	[3.600]	[3.200]		
60.96	78.74	72.64	82.80	78.74	68.58	50	1-102153-0
[2.400]	[3.100]	[2.860]	[3.260]	[3.100]	[2.700]		
48.26	66.04	59.94	70.10	66.04	55.88	40	102153-9
[1.900]	[2.600]	[2.360]	[2.760]	[2.600]	[2.200]		
40.64	58.42	52.32	62.48	58.42	48.26	34	102153-8
[1.600]	[2.300]	[2.060]	[2.460]	[2.300]	[1.900]		
35.56	53.34	47.24	57.40	53.34	43.18	30	102153-7
[1.400]	[2.100]	[1.860]	[2.260]	[2.100]	[1.700]		
30.48	48.26	42.16	52.32	48.26	38.10	26	102153-6
[1.200]	[1.900]	[1.660]	[2.060]	[1.900]	[1.500]		
27.94	45.72	39.62	49.78	45.72	35.56	24	102153-5
[1.100]	[1.800]	[1.560]	[1.960]	[1.800]	[1.400]		
22.86	40.64	34.54	44.70	40.64	30.48	20	102153-4
[.900]	[1.600]	[1.360]	[1.760]	[1.600]	[1.200]		
17.78	35.56	29.46	39.62	35.56	25.40	16	102153-3
[.700]	[1.400]	[1.160]	[1.560]	[1.400]	[1.000]		
15.24	33.02	26.92	37.08	33.02	22.86	14	102153-2
[.600]	[1.300]	[1.060]	[1.460]	[1.300]	[.900]		
10.16	27.94	21.84	32.00	27.94	17.78	10	102153-1
[.400]	[1.100]	[.860]	[1.260]	[1.100]	[.700]		
F	E	D	C	B	A	NO OF POSN	PART NUMBER

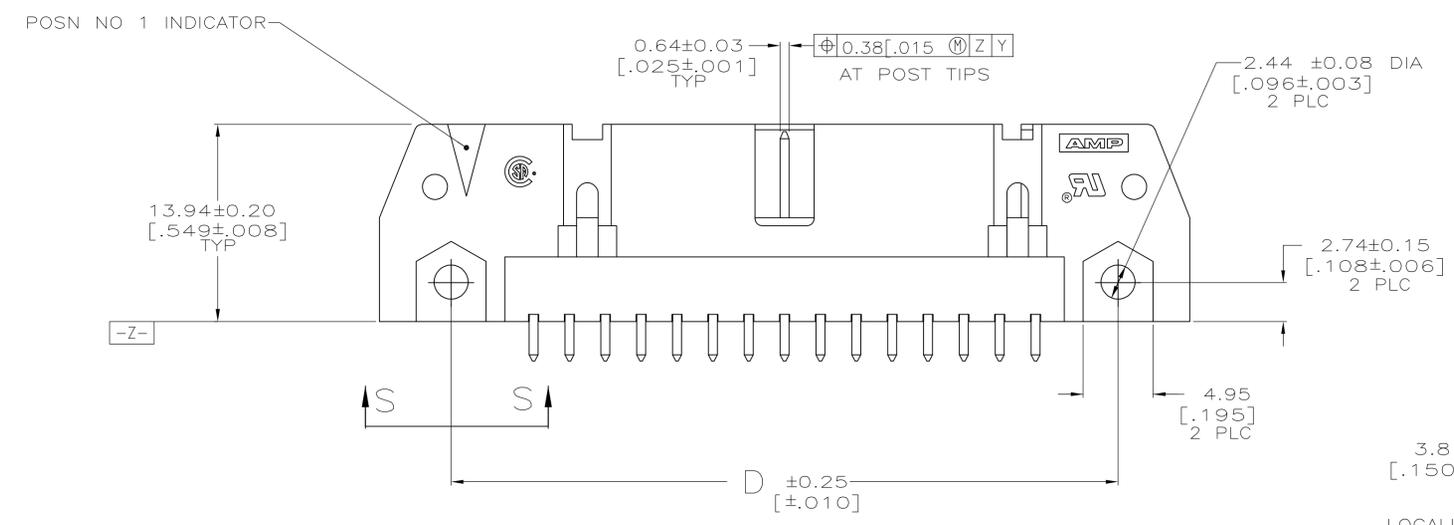
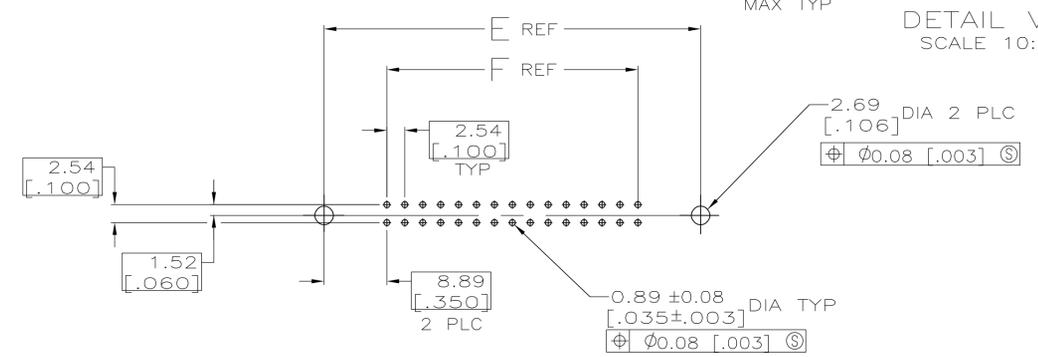
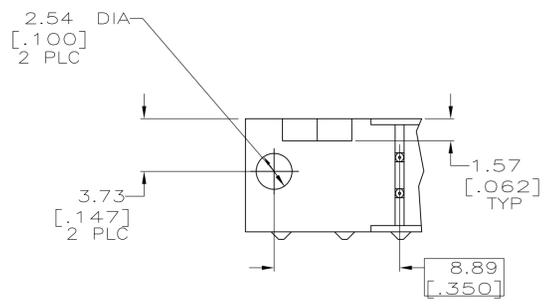

THIS DRAWING IS A CONTROLLED DOCUMENT. 4-23-90

DIMENSIONS: mm [INCHES]

TOLERANCES UNLESS OTHERWISE SPECIFIED:

0 PLC	±	-
1 PLC	±	-
2 PLC	±	0.13[0.005]
3 PLC	±	-
4 PLC	±	-
ANGLES	±	-

MATERIAL: ⑥ FINISH: ⑤

APVD: H. MOLL

NAME: Tyco Electronics Corporation, Harrisburg, PA 17105-3608

PRODUCT SPEC: 108-40018

APPLICATION SPEC: -

SIZE: A1

WEIGHT: -

CUSTOMER DRAWING: 100779

SCALE: 4:1

SHEET: 1 of 1

REV: K